



# **HEIGHT ADJUSTABLE TABLE**

**USER GUIDE**

This page was intentionally left blank.

# TABLE OF CONTENTS

<b>Parts Diagram</b>	4-5
Adjustable L-Rail	4
Three-Leg	5
<b>Safety Information</b>	6-7
<b>Assembly Instructions</b>	8-11
<b>Operation</b>	12-13
Initialization and Reset	12
Handswitch Operation	12
Programmable Handswitch Operation	12-13
- Change the Height Unit	13
- Change the Height Display	13
- Save Memory Position	13
- Recall Memory Position	13
<b>Troubleshooting</b>	14-15
Unit Errors	14
Handswitch Errors	15
<b>Technical Data</b>	16
Warranty	17

This manual explains how this sit-stand desk is assembled, used, and maintained. All sit-stand tables are subjected to functional and quality tests before leaving our facility.

**ADJUSTABLE L-RAIL**

For tables up to 84"

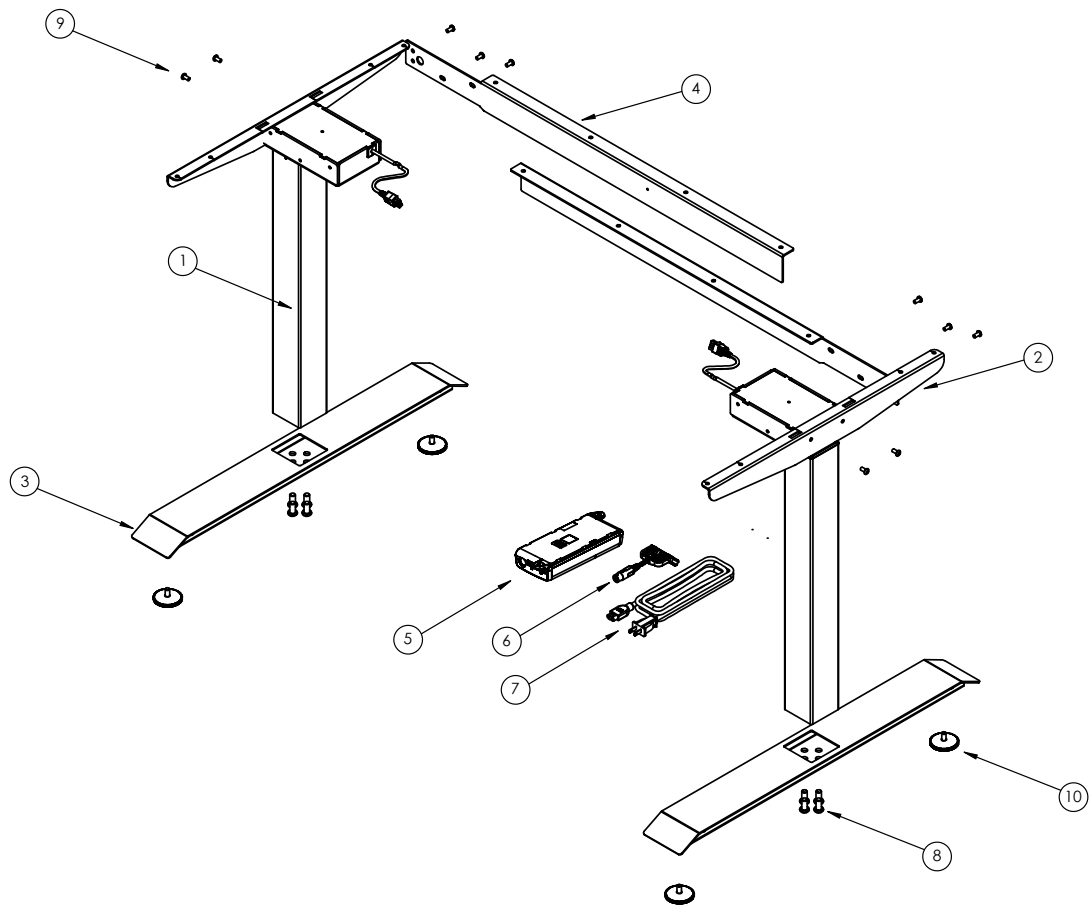
**PARTS****Qty/Package**

1.	Column	2
2.	Top Support	2
3.	Foot	2
4.	Adjustable L-Rail	2
5.	Control Box	1
6.	Handswitch	1
7.	Power Cord	1
8.	M10x1.5 20mm Screw	4
9.	M6x1.0 12mm Screw	10
10.	Glide	4

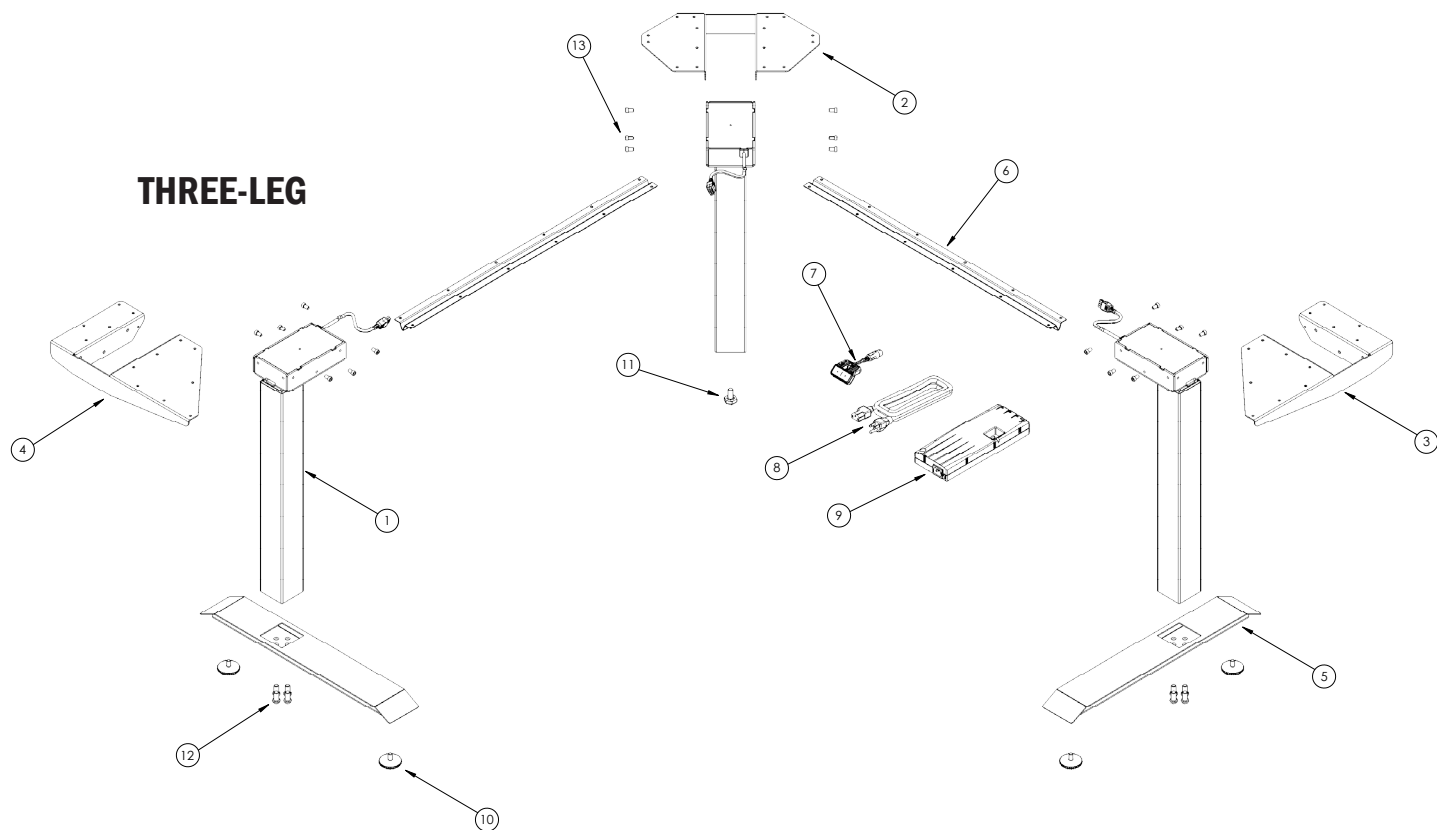

**PARTS** Qty/Package

1.	Column	3
2.	Top Support (Third Leg)	1
3.	Top Support (Right Hand)	1
4.	Top Support (Left Hand)	1
5.	Foot	2
6.	Support Bar	2
7.	Handswitch	1
8.	Power Cord	1
9.	Control Box	1
10.	Glide	4
11.	Hex Leveler	1
12.	M10 X 1.5 20mm Screw	8
13.	M6 X 1.0 12mm Screw	18

# SAFETY INFORMATION

## IMPORTANT SAFETY INSTRUCTIONS *Save these instructions.*

### **DANGER** To reduce the risk of electric shock:

Always unplug the furnishing from the electrical outlet before cleaning or servicing.

**WARNING:** Risk of Electric Shock, Fire and Injury – Review the assembly instructions to confirm that the appropriate critical components and accessories are being used with the furnishing. Do not change or replace components and accessories provided by the manufacturer.

## INSTALL ONLY APPROVED WORK SURFACES

This table system does not include a work surface (desktop). Work surface must be at least  $\frac{3}{4}$ " thick and weigh no more than 5 lb. per square foot (For example, a 2"x6" desktop should weigh no more than 60 lb). Do not exceed a maximum weight for the desktop of 75 lb. To prevent table from tipping or collapsing, make sure the desk frame is not overloaded by the weight of tabletop and objects you plan to put on the table. If you are unsure, contact customer service.

## KEEP AWAY FROM CHILDREN

This table system is not designed for use in homes or other areas accessible by small children. For indoor commercial office use only.

## BE CAREFUL WHEN ADJUSTING DESK HEIGHT

Body parts and property can be caught between the moving work surface and an immobile obstacle (such as shelves, furniture, window sills, or walls). Keep at least one inch of clearance around desk and make sure nothing is in table's path for its entire range of motion.

### **Before raising or lowering:**

- Check surroundings on all sides of desk are clear
- Make sure corded objects will not be pulled off table or cause other objects to fall
- Make sure desk power cord moves freely as desk moves up and down

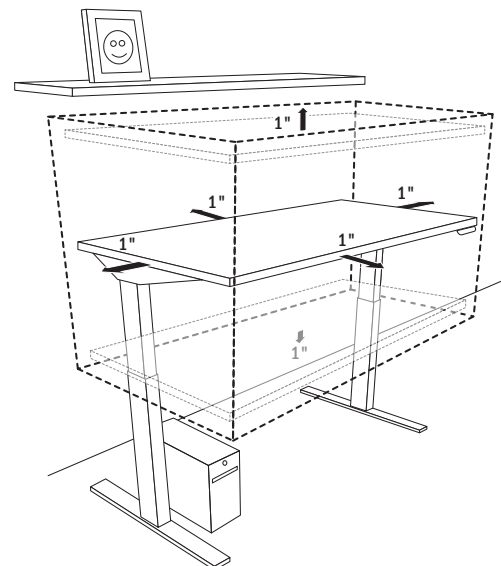

## DO NOT OVERLOAD DESK

To prevent table from tipping or collapsing, make sure the desk frame is not overloaded by the weight of tabletop and objects on table. Evenly distribute load; excess loads near edges can reduce stability and lead to tip over.

- Do not exceed maximum load (including weight of desktop) of 225 lb. (102 Kg)
- Do not exceed edge load of 25 lb. when positioning monitors or mounting accessories.
- Do not sit or stand on table

## USE CARE WHEN MOVING DESK

- Clear objects and equipment from table before moving to reduce the risk of tipping over.
- Adjust the desk to its lowest height before moving
- To disconnect, remove plug from outlet
- Do not move a loaded desk

## DO NOT OPEN ELECTRICAL COMPONENTS

Do not attempt to service table components. There are no user-serviceable parts inside the motor control units or table legs. If your table needs service, contact customer service. Never operate this workstation if it has a damaged cord or plug.

## KEEP TABLE FRAME DRY

Keep all electrical components away from water and high humidity. Clean only with a dry or slightly damp cloth. Do not spray cleaning solutions directly onto table system.

## GROUNDING INSTRUCTIONS

This product may be equipped with a cord having an equipment-grounding conductor and a grounding plug. **Use only the cord provided.** Make sure that the product is connected to an outlet having the same configuration as the plug (as shown in Illustration A) that is properly installed and grounded in accordance with all local codes and ordinances.

Do not modify the plug provided with the product – if it will not fit the outlet, have a proper outlet installed by a qualified electrician.

**No adapters are to be used with this product.**  
**Keep cord away from heated surfaces.**

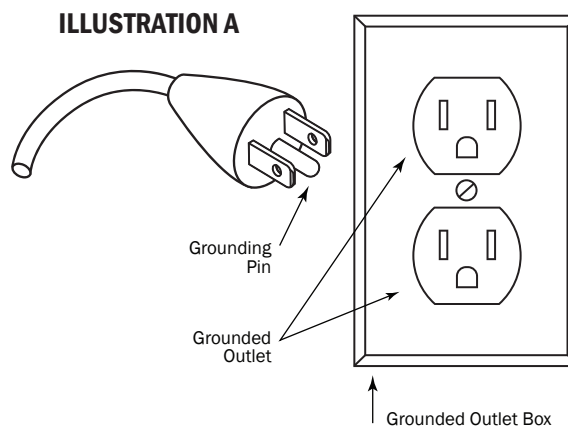

# ASSEMBLY INSTRUCTIONS

The assembly of the table frame to be made in accordance with this manual. Changes to the table frame or improper use may affect the safety, function, and life of your product.

*This manual is for all sit-stand tables from the series.  
Due to different models or types, pictures may vary.*

## ASSEMBLY OVERVIEW

- 1a.** Assemble the third column to the adapter brackets
- 1.** Assemble the column to the L-rail
- 2.** Assemble the top support to the column
- 3.** Assemble the foot to the column
- 4.** Fasten the table frame onto the table top
- 5.** Fasten the control box and handswitch to the table top
- 6.** Connect the motor cables to the control box
- 7.** Connect the handswitch (HS) cable to the control box
- 8.** Connect the supplied power cord (AC) to the control box
- 9.** Attach all cables to the table frame or on the underside of the table top

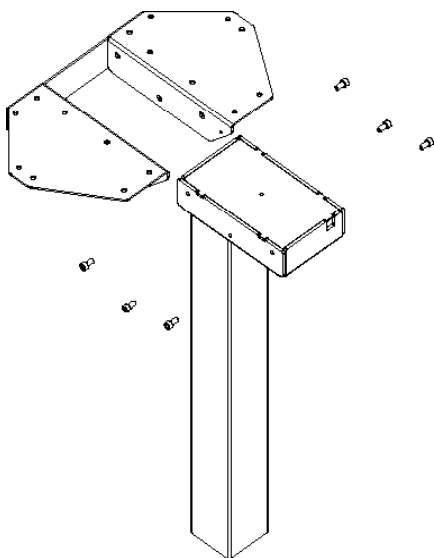

If you have any difficulty assembling this unit or need to order replacement parts, please contact our Customer Service department. Use the parts diagrams on page 4-7 as a reference.

### **1a** ASSEMBLE THE THIRD COLUMN TO THE ADAPTER BRACKETS (FOR THIRD LEG ASSEMBLY ONLY)

Assemble using the M6x1.0 12mm length screws (6 shown in diagram). The maximum tightening torque for these screws is 9.9Nm (7.3 ft-lbs)



## 1 ASSEMBLE THE COLUMN TO THE J-RAIL

Assemble using the M6x1.0 12mm length screws (6 per column). The maximum tightening torque for these screws is 9.9Nm (7.3 ft-lbs)

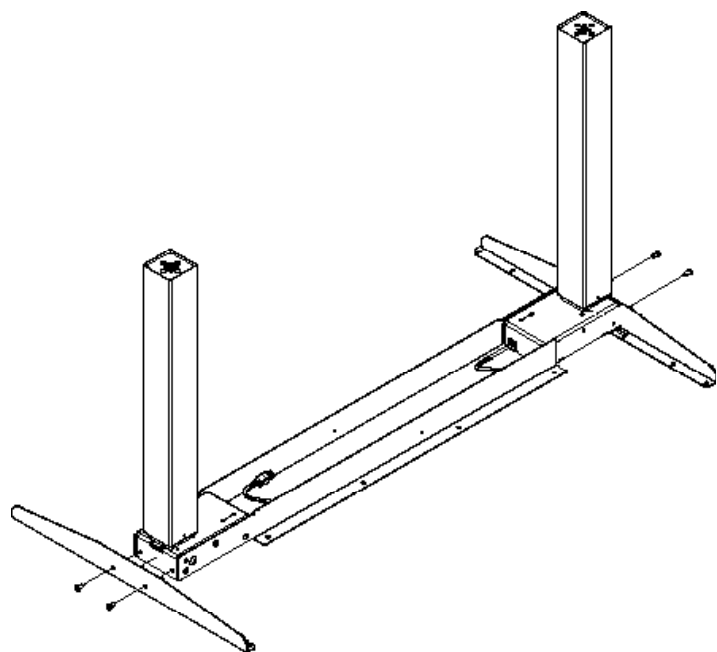

## 3 ASSEMBLE THE FOOT TO THE COLUMN

Assemble using the M10x1.5 x 20mm length screws (4 per column). The maximum tightening torque for these screws is 11Nm. (8 ft-lbs).

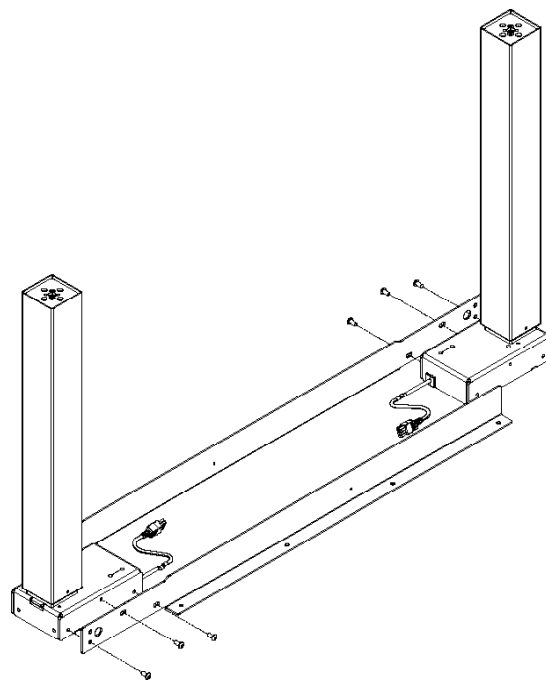

## 2 ASSEMBLE THE TOP SUPPORT TO THE COLUMN

Assemble using the M6x1.0 12mm length screws (2 per top support). The maximum tightening torque for these screws is 9.9Nm (7.3 ft-lbs)

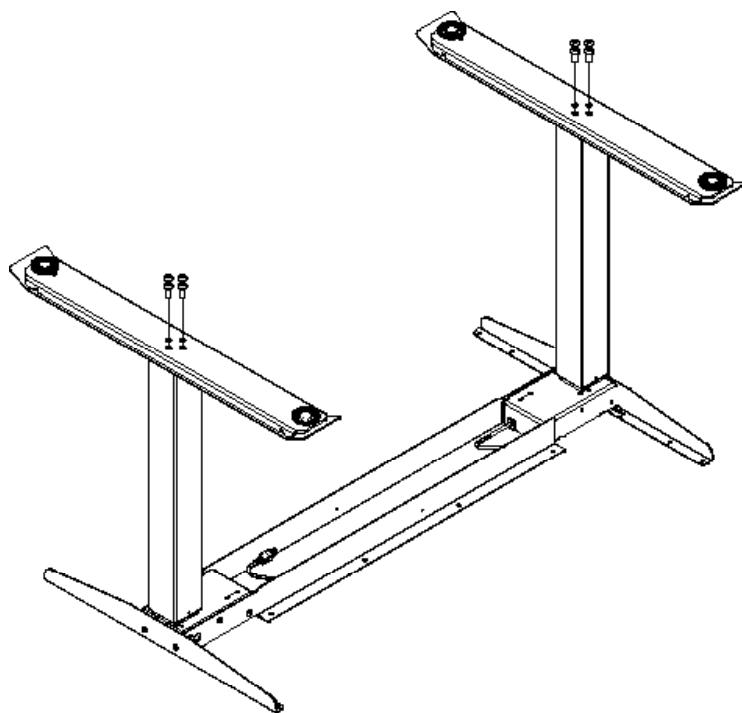

# 4 FASTEN THE TABLE FRAME ONTO THE TABLE TOP

Be sure to use approved screws per the table top supplier.

ADJUSTABLE L-RAIL

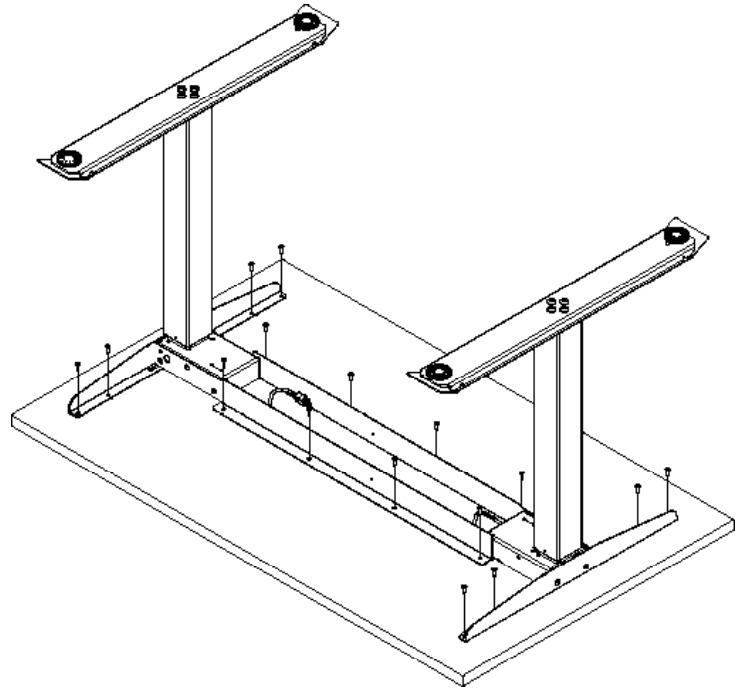

THREE-LEG

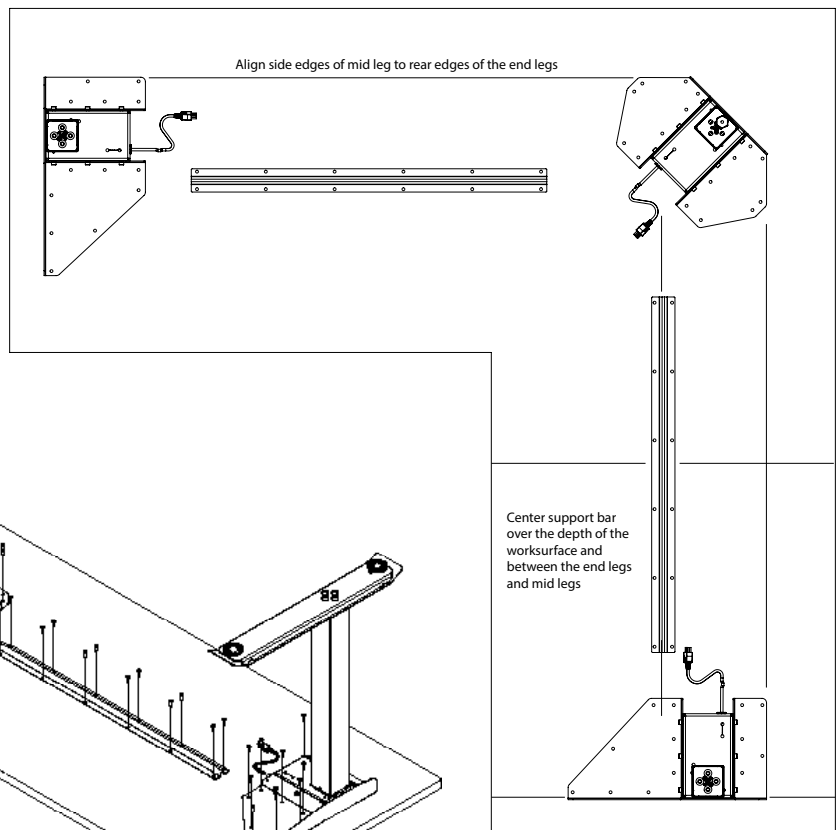
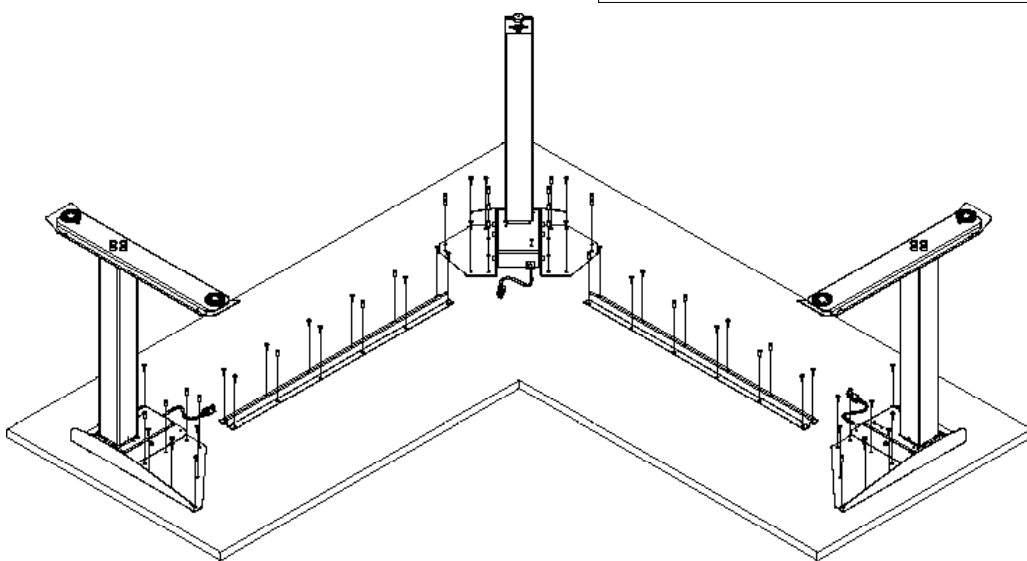

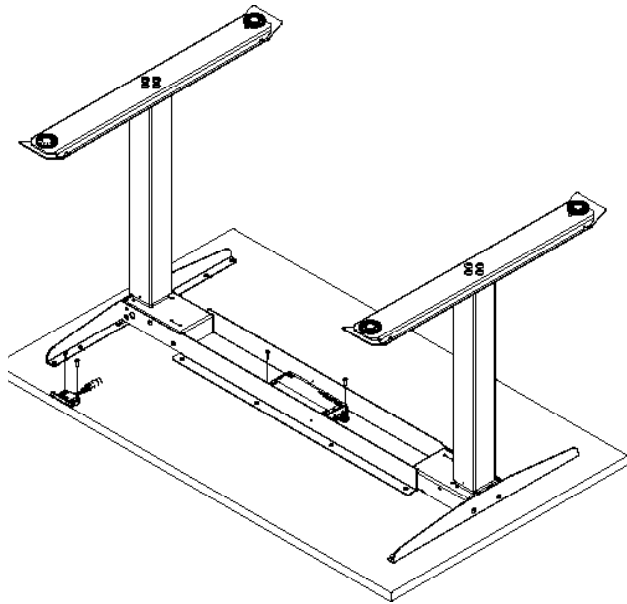

## 5 FASTEN THE CONTROL BOX AND HANDSWITCH TO THE TABLE TOP

Make sure the control box and handswitch are fastened in a location where all the cables will connect without being in tension. Be sure to use approved screws per the table top supplier.

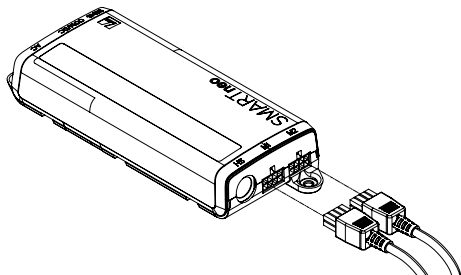

## 6 CONNECT THE MOTOR CABLES TO THE CONTROL BOX

The motor cable plug-connection has to click into place.

Connections to the control box:

M1-M2 = Connectors for the columns

HS = Connectors for the handset

AC = Connector for the power cord (3-pin)

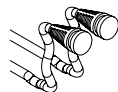
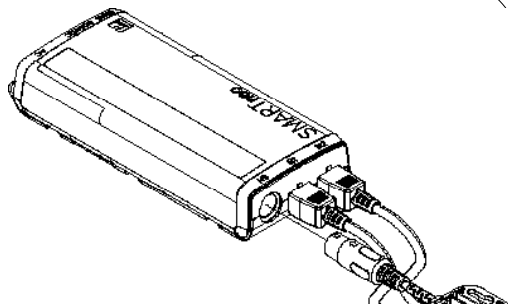

## 7 CONNECT THE HANDSWITCH (HS) CABLE TO THE CONTROL BOX

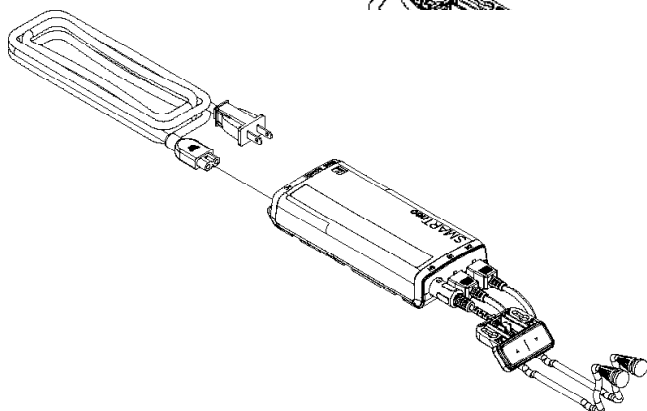

## 8 CONNECT THE SUPPLIED POWER CORD (AC) TO THE CONTROL BOX

## 9 ATTACH ALL CABLES TO THE TABLE FRAME OR ON THE UNDERSIDE OF THE TABLE TOP

Attach cables in order to avoid any damage during operation. **Never attach cables and cords to legs.**

# OPERATION INFORMATION

## INITIALIZATION/RESET

The desk must be initialized/reset after any of the following:

- After assembly
- After disconnection from the power supply
- After any impact on the table top.

To initialize/reset, move the table to the lowest position by pressing the DOWN button on the handswitch until the columns reach the lowest position. Press the DOWN button again until the table moves slightly down to the machine zero point and back up to the operation zero point. Release the DOWN button. If the button is released too soon, the table legs will not move up. Repeat the reset process.

The control box is programmed with a parameter file which controls the table legs' lower and upper travel limits. **Under no circumstance should a control box from one table be moved to another.**

## NORMAL HANDSWITCH OPERATION (for all handswitch types)

By pressing the UP or DOWN buttons, the table will move up or down to the desired position. Once the desired position is reached, let go of the UP or DOWN button. The table legs will stop once they reach the lower or upper height limits.

## PROGRAMMABLE HANDSWITCH OPERATION (optional)

This programmable handswitch is equipped with a display for showing the current table height in centimeters or inches.

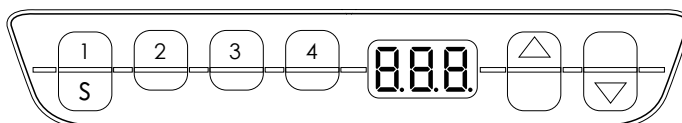

The handswitch also will display an error code if an error is detected by the control box. When an error is detected, the display will show an error code "EXX," instead of the current table height. To resolve the error, see the Troubleshooting Section (p. 16-17 of this guide).

The programmable handswitch also has the ability to save up to four different height positions.

## **PROGRAMMABLE HANDSWITCH OPERATION** (continued)

### **CHANGE THE HEIGHT UNIT** (inches or centimeters)

The handswitch can display the table height in either centimeters or inches. With the help of the S5-menus, the unit of measure can be changed.

To change the unit of measure, follow these steps:

1. Press and hold the 1, 2, and UP buttons until the display shows "S 5".
2. Confirm by pressing the "S" button. Now the display will have changed.

To exit the menu without making a selection, wait until the height display appears again.

### **CHANGE THE HEIGHT DISPLAY**

If the displayed value does not match the actual height of the table top, the display can be corrected as follows:

1. Press and release the "S" button.
2. Press and hold the DOWN button until the display starts to flash.
3. Change the height shown on the handswitch by pressing the UP or DOWN button to the desired height. Confirm by pressing the "S" button.

To exit the menu without making a selection, wait until the height display appears again.

### **SAVE MEMORY POSITION**

1. Move the table up or down to the desired height.
2. Press the "S" button (in the display "S -" is shown.)
3. Select a position by pressing one of the four number buttons, 1-4, (if 1 is selected, the display will show the setting as "S1").
4. The saved position is confirmed by a double click sound from the control box. The display shows the current table height. Repeat steps to save a maximum of four different positions.

### **RECALL MEMORY POSITION**

Press and hold the desired memory button (1, 2, 3 or 4) the table moves from the current position into the saved position. The button must be pressed until the position is reached. If the button is released, the table will stop short of the desired height.

# TROUBLESHOOTING

## UNIT

ERROR CODE	SOURCE	SOLUTION
<b>Table does not move</b>	No power supply	Plug in the power cord or check the connection on the control box
	No connection or a loose connection to the drives	Verify the plug connections of the motor cable to the control box
	No connection or a loose connection to the handswitch	Verify the plug connections of the motor cable to the control box
	Max lifting capacity is exceeded	Reduce the weight or load on the desktop
	Max time limit is exceeded	Control is activated automatically after approx. 9 minutes
	Defective drive	<b>Contact customer service</b>
	Defective control box	<b>Contact customer service</b>
	Defective handswitch	Replace the handswitch
<b>Table moves down at a slow rate</b>	Control box expects new reset	Reset control box. (See Operation Information)
<b>During operation, tables moves at a slow rate</b>	Max lifting capacity is exceeded	Reduce weight
<b>Table moves on one side only briefly and then stops</b>	No connection or a loose connection to the drives	Verify the plug connections of the motor cable to the control box and reset the control box
	Defective drive	<b>Contact customer service</b>

## HANDSWITCH DISPLAY

ERROR CODE	SOURCE	SOLUTION
<b>HOT</b>	The control box monitors the duty cycle (time-controlled) and its max temperature. A value has been exceeded.	Wait until the "HOT" display goes out - the table is working properly again
<b>E00</b>	M1 - Internal Fault	Unplug and <b>contact customer service</b>
<b>E01</b>	M2 - Internal Fault	
<b>E02</b>	M3 - Internal Fault	
<b>E12</b>	M1 - Defect	Unplug. Correct the external short circuit and/or verify the cable to the drives. Plug cables into the control box and re-run table.
<b>E13</b>	M2 - Defect	
<b>E14</b>	M3 - Defect	
<b>E24</b>	M1 - Overcurrent	Collision → resolve if necessary
<b>E25</b>	M2 - Overcurrent	Max load exceeded → remove excess load from the table
<b>E26</b>	M3 - Overcurrent	If the problem still exists, please <b>contact customer service</b>
<b>E36</b>	M1 - Not connected	Motor not connected. Check cable / connector to the drive. Reset the table (See Operation Information)
<b>E37</b>	M2 - Not connected	
<b>E38</b>	M3 - Not connected	
<b>E48</b>	Overcurrent drive 1	Collision → resolve if necessary
<b>E49</b>	Overcurrent drive 2	Max load exceeded → remove excess load from the table
<b>E55</b>	Drive 1 - Synchronization is lost	If necessary, reduce the load on the table
<b>E56</b>	Drive 2 - Synchronization is lost	Reset the table (See Operation Information)
<b>E60</b>	Collision identified	Option ISP function. Remove source.
<b>E61</b>	Drive replaced	The connection to the drive is interrupted or a new drive is connected. Reset the table (See Operation Information)

If it is not possible to resolve an error as described, disconnect the power cord, wait a few minutes and reset the table again.  
If the error still occurs, remove the table from the power source and contact customer service.

(Error Code list is valid from firmware 1.7.5 and higher)

Lorem ipsum

# TECHNICAL DATA

GENERAL CONTROL BOX	
<b>Power supply</b>	120 VAC $\pm$ 10% / 60 Hz
<b>Standby power consumption, primarily</b>	<0.3 W
<b>Operating temperature</b>	0-35°C
<b>Protection class</b>	IP 20
<b>Maximum power output</b>	216VA/24V

TWO-COLUMN FRAME WITH CONTROL BOX	
<b>Maximum lift capacity</b>	225 lb ( $\approx$ 102kg / 1000N)
<b>Adj. range, depending on version</b>	View Illustration B
<b>Maximum input current</b>	5 A
<b>Maximum duty cycle</b>	5% (1 min. on / 18 min. off)

ILLUSTRATION B

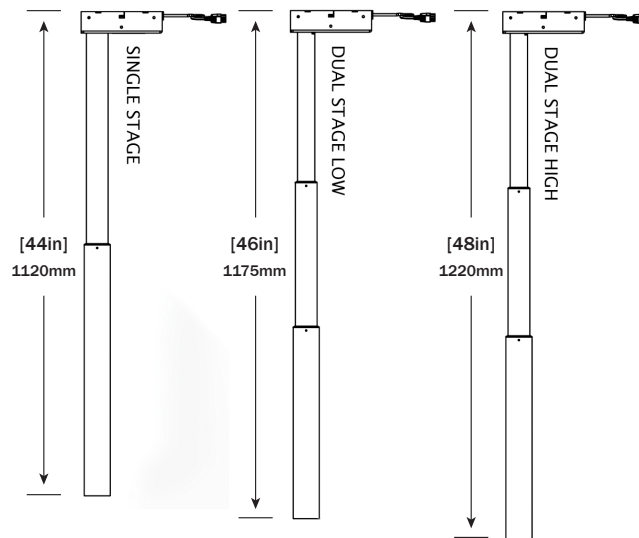



# WARRANTY

**CONTACT YOUR SALES REPRESENTATIVE FOR WARRANTY INFORMATION**



End of life cycle: Once product is disassembled, all steel components can be recycled at your local metal collector. For products with electronic components, see Disassembly Guide.

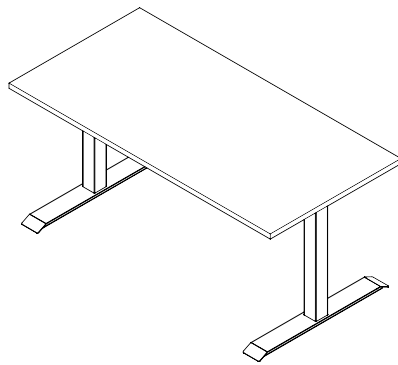

# **USER GUIDE**