



HEIGHT ADJUSTABLE TABLE

USER GUIDE

This page was intentionally left blank.

TABLE OF CONTENTS

Parts Diagram	4
Full Length 48"	4
Full Length 54"-72"	5
Safety Information	6-7
Assembly Instructions	8-12
Operation	13-14
Initialization and Reset	13
Handswitch Operation	13
Programmable Handswitch Operation	13
- Change the Height Unit	14
- Adjust Height Display	14
- Save Memory Position	14
- Recall Memory Position	14
Troubleshooting	15-16
Unit Errors	15
Handswitch Errors	16
Technical Data	17
Standards & Certifications	18

This manual explains how this sit-stand desk is assembled, used, and maintained. All sit-stand tables are subjected to functional and quality tests before leaving our facility.

PARTS DIAGRAM

FULL LENGTH

For tables 48"

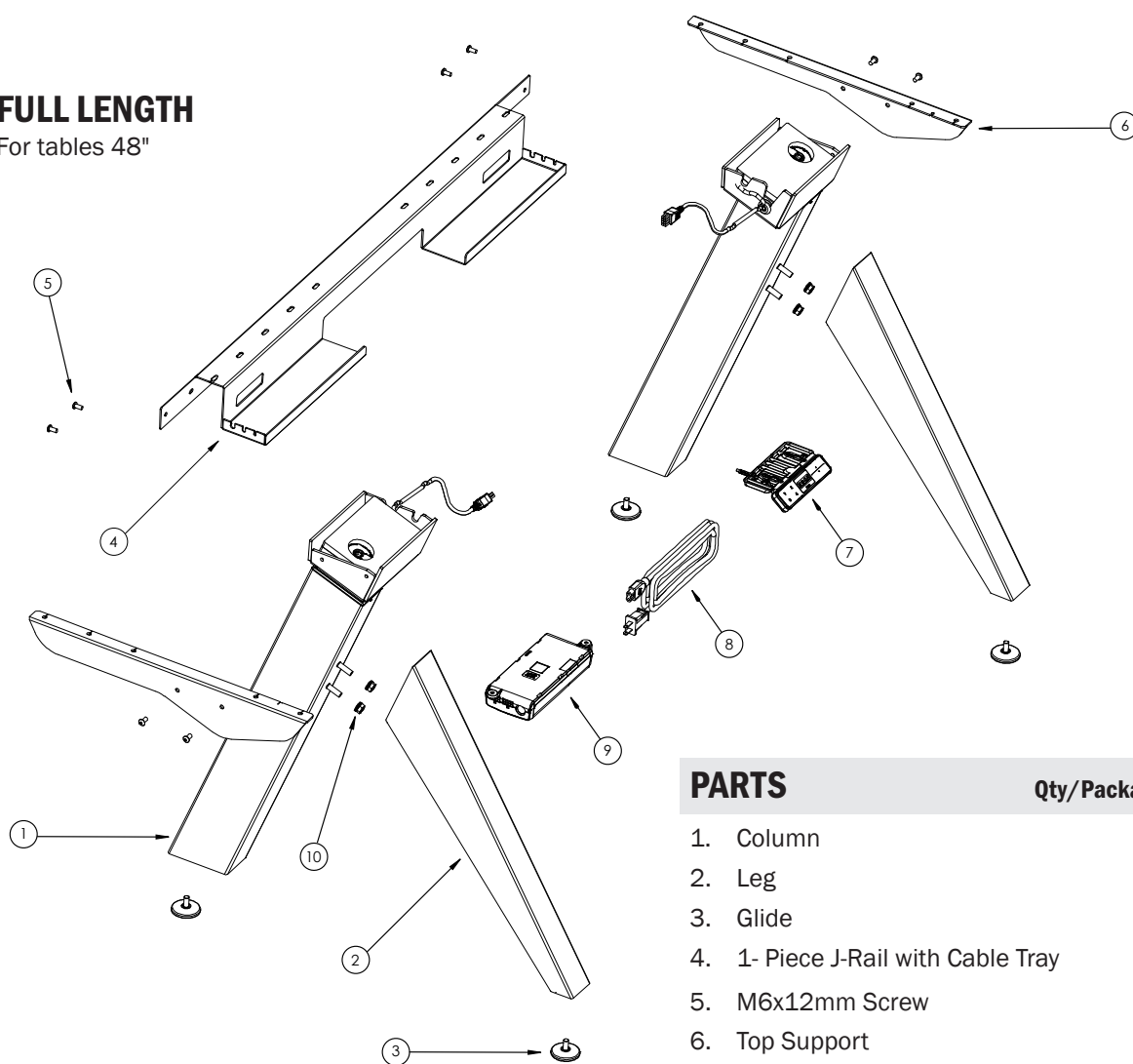

PARTS

Qty/Package

1. Column	2
2. Leg	2
3. Glide	4
4. 1- Piece J-Rail with Cable Tray	1
5. M6x12mm Screw	16
6. Top Support	2
7. Programmable Handswitch	1
8. Power Cord	1
9. Control Box	1
10. M8 Nut Hex	4

PARTS DIAGRAM

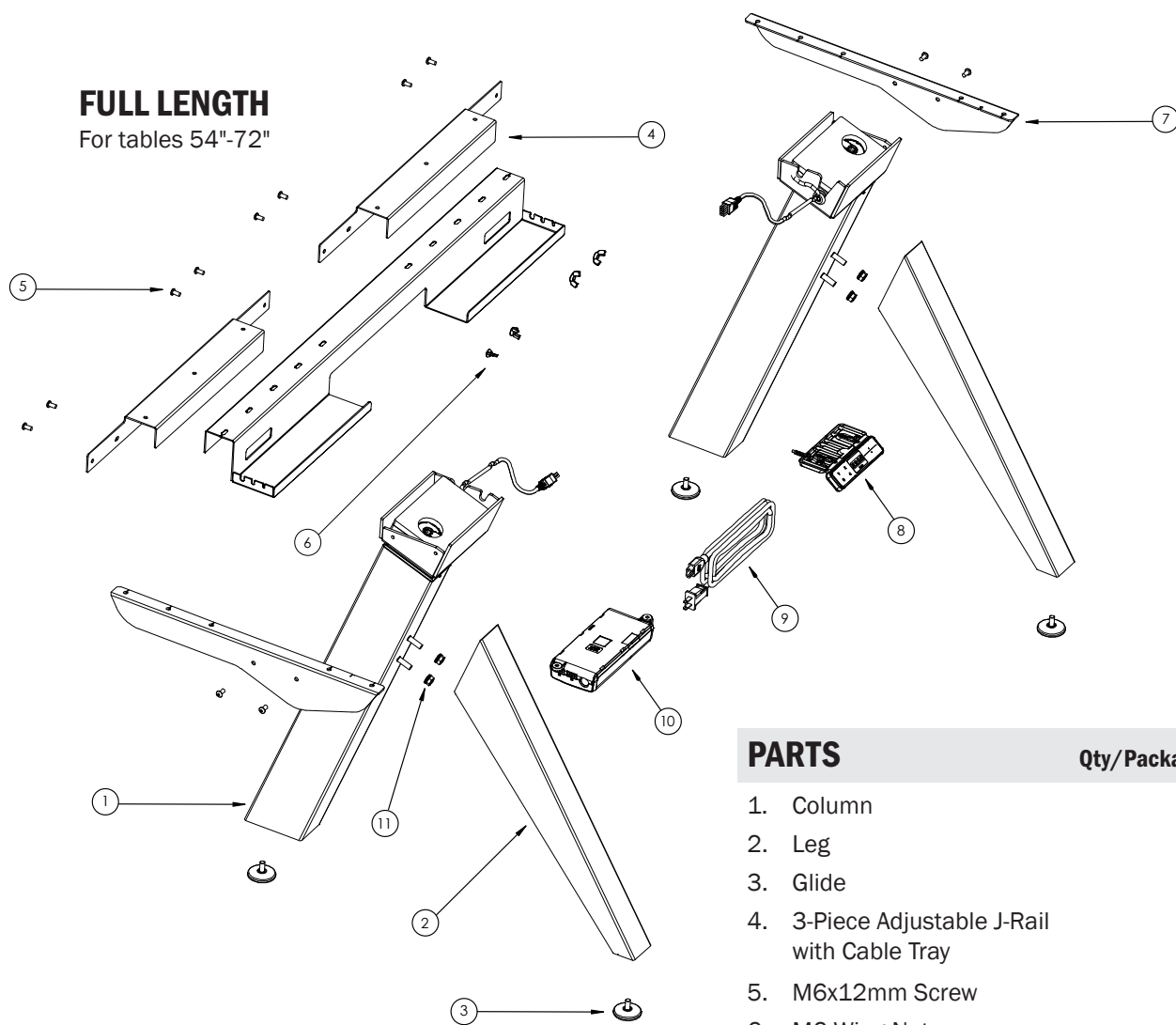

PARTS

Qty/Package

1.	Column	2
2.	Leg	2
3.	Glide	4
4.	3-Piece Adjustable J-Rail with Cable Tray	1
5.	M6x12mm Screw	20
6.	M6 Wing Nut	4
7.	Top Support	2
8.	Programmable Handswitch	1
9.	Power Cord	1
10.	Control Box	1
11.	M8 Nut Hex	4

SAFETY INFORMATION

IMPORTANT SAFETY INSTRUCTIONS *Save these instructions.*

DANGER To reduce the risk of electric shock:

Always unplug this furnishing from the electrical outlet before cleaning.

WARNING: To reduce the risk of death, serious injury, or property damage, read and follow this safety information and the provided instructions when assembling this product. Do not change or replace components and accessories provided by the manufacturer.

INSTALL ONLY APPROVED WORK SURFACES

This table system does not include a work surface (desktop). Work surface must be at least $\frac{3}{4}$ " thick and weigh no more than 5 lb. per square foot (For example, a 2'x6' desktop should weigh no more than 60 lb). Do not exceed a maximum weight for the desktop of 75 lb. To prevent table from tipping or collapsing, make sure the desk frame is not overloaded by the weight of tabletop and objects you plan to put on the table. If you are unsure, contact customer service.

KEEP AWAY FROM CHILDREN

This table system is not designed for use in homes or other areas accessible by small children. For indoor commercial office use only.

BE CAREFUL WHEN ADJUSTING DESK HEIGHT

Body parts and property can be caught between the moving work surface and an immobile obstacle (such as shelves, furniture, window sills, or walls). Keep at least one inch of clearance around desk and make sure nothing is in table's path for its entire range of motion.

Before raising or lowering:

- Check surroundings on all sides of desk are clear
- Make sure corded objects will not be pulled off table or cause other objects to fall
- Make sure desk power cord moves freely as desk moves up and down

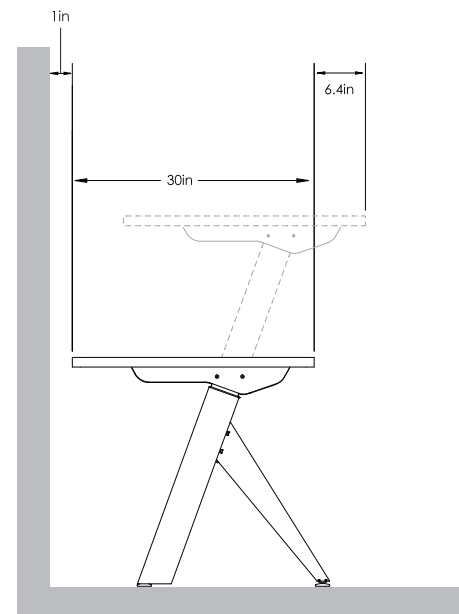

DO NOT OVERLOAD DESK

To prevent table from tipping or collapsing, make sure the desk frame is not overloaded by the weight of tabletop and objects on table. Evenly distribute load; excess loads near edges can reduce stability and lead to tip over.

- Do not exceed maximum load (including weight of desktop) of 225 lb. (102 Kg)
- Do not exceed edge load of 25 lb. when positioning monitors or mounting accessories.
- Do not sit or stand on table

USE CARE WHEN MOVING DESK

- Clear objects and equipment from table before moving to reduce the risk of tipping over.
- Adjust the desk to its lowest height before moving
- To disconnect, remove plug from outlet
- Do not move a loaded desk

DO NOT OPEN ELECTRICAL COMPONENTS

Do not attempt to service table components. There are no user-serviceable parts inside the motor control units or table legs. If your table needs service, contact customer service. Never operate this workstation if it has a damaged cord or plug.

KEEP TABLE FRAME DRY

Keep all electrical components away from water and high humidity. Clean only with a dry or slightly damp cloth. Do not spray cleaning solutions directly onto table system.

GROUNDING INSTRUCTIONS

This product may be equipped with a cord having an equipment-grounding conductor and a grounding plug. **Use only the cord provided.** Make sure that the product is connected to an outlet having the same configuration as the plug (as shown in Illustration A) that is properly installed and grounded in accordance with all local codes and ordinances.

Do not modify the plug provided with the product – if it will not fit the outlet, have a proper outlet installed by a qualified electrician.

No adapters are to be used with this product.
Keep cord away from heated surfaces.

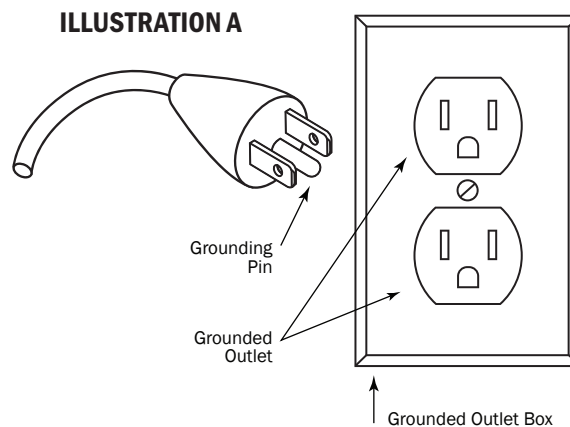

ASSEMBLY INSTRUCTIONS

The assembly of the table frame to be made in accordance with this manual. Changes to the table frame or improper use may affect the safety, function, and life of your product.

*This manual is for all sit-stand tables from the series.
Due to different models or types, pictures may vary.*

ASSEMBLY OVERVIEW

1. Assemble the top support to the column
2. Assemble the column to the j-rail
3. Assemble the leg to the column
4. Fasten the table frame onto the table top
5. Fasten the control box and handswitch to the table top
6. Connect the motor cables to the control box
7. Connect the handswitch (HS) cable to the control box
8. Connect the supplied power cord (AC) to the control box
9. Attach all cables to the cable tray

If you have any difficulty assembling this unit or need to order replacement parts, please contact our Customer Service department. Use the parts diagrams on pages 4-5 as a reference.

1 ASSEMBLE THE TOP SUPPORT TO THE COLUMN

Assemble using the M6x12mm length screws (2 per top support). The maximum tightening torque for these screws is 9.9Nm (7.3 ft-lbs)

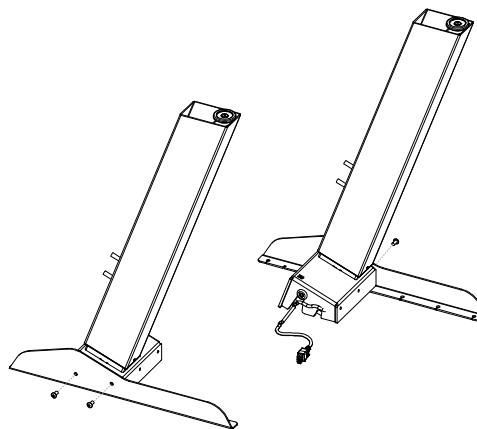

2 ASSEMBLE THE COLUMN TO THE J-RAIL

Assemble using the M6x12mm length screws (2 per column). The maximum tightening torque for these screws is 9.9Nm (7.3 ft-lbs)

1-PIECE J-RAIL CABLE TRAY
(48" tables)

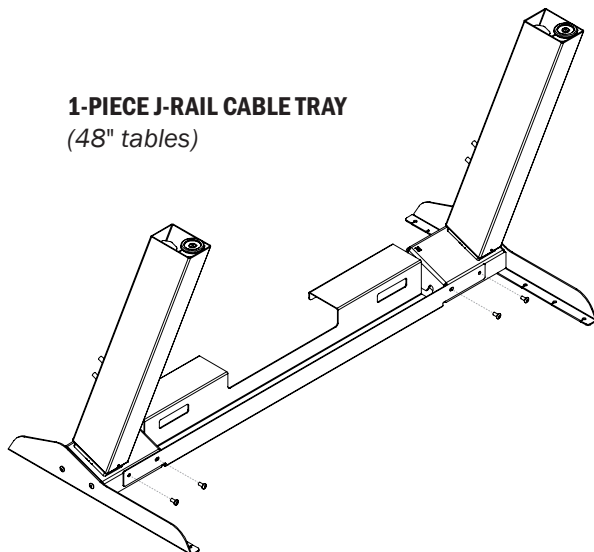

3-PIECE ADJUSTABLE J-RAIL CABLE TRAY
(54"-72" tables)

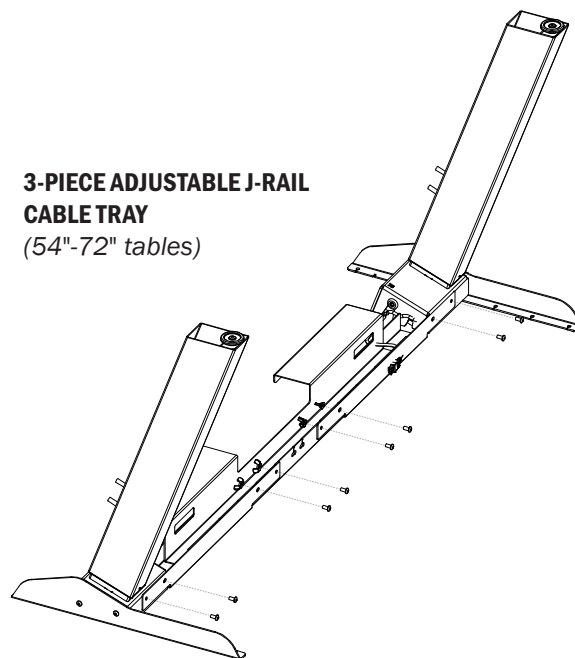

3 ASSEMBLE THE LEG TO THE COLUMN

Assemble using the M8 hex nuts (2 per leg).

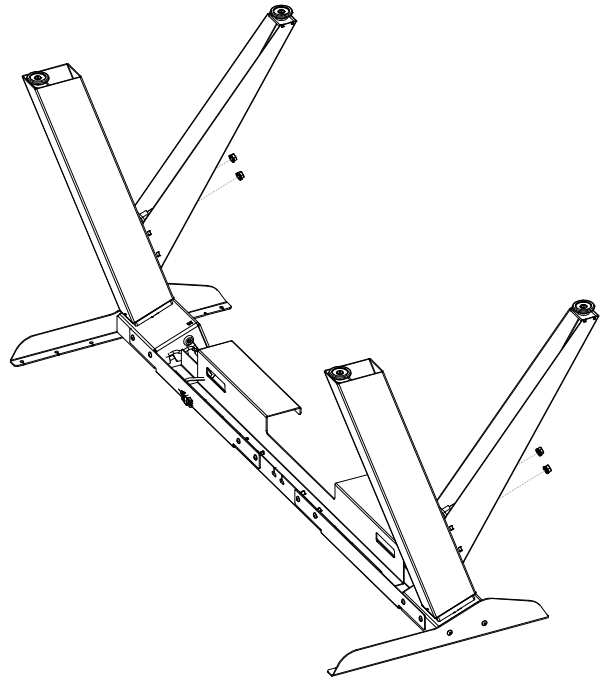

a PRE-INSTALL THE HEX NUTS

Partially install the M8 hex nuts onto column studs (about halfway).

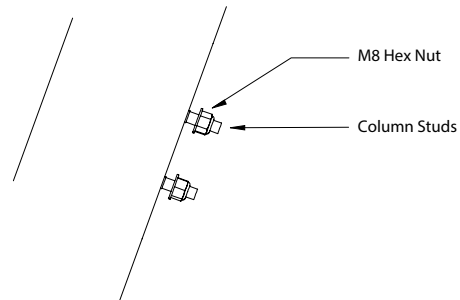

b INSTALL LEG OVER THE HEX NUTS

Using keyhole openings, install the leg over the hex nuts and slide studs into the small slots. Tighten the hex nuts the rest of the way. The maximum tightening torque for these is 13.5Nm (10 ft-lbs).

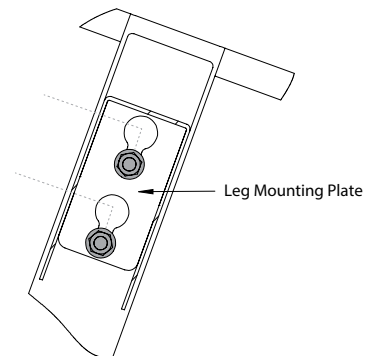

4 FASTEN THE TABLE FRAME ONTO THE TABLE TOP

Center frame on the table top, ensuring that top supports are of equal distance from the work surface's edge. **Be sure to use approved screws per the table top supplier.**

Top supports should be mounted 3" from front edge of work surface as shown.

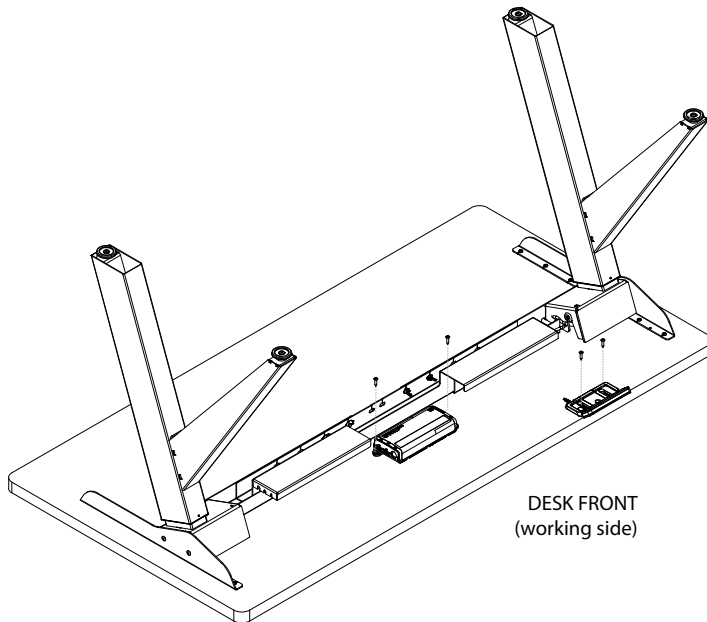
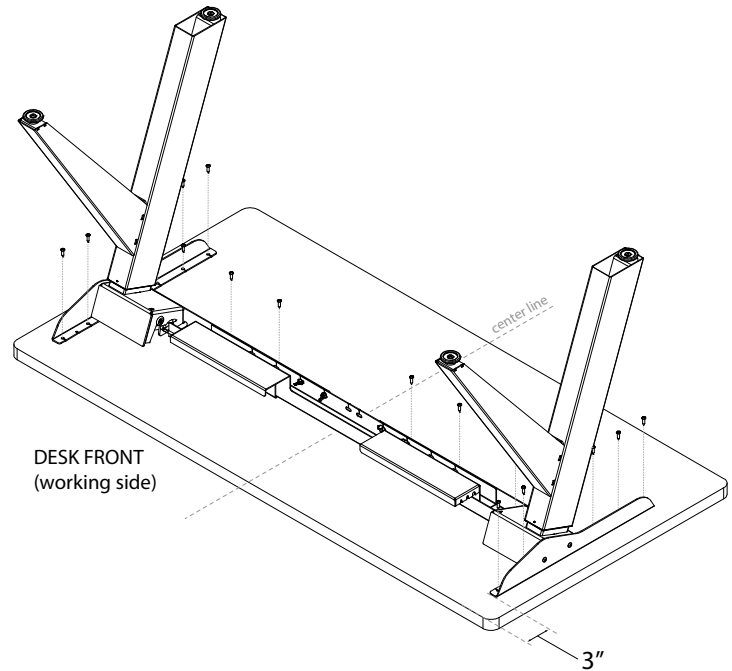

5 FASTEN THE CONTROL BOX AND HANDSWITCH TO THE TABLE TOP

Make sure the control box and handswitch are fastened in a location where all the cables will connect without being in tension. Be sure to use approved screws per the table top supplier.

Recommended: mount control box in line with cable tray in opening as shown.

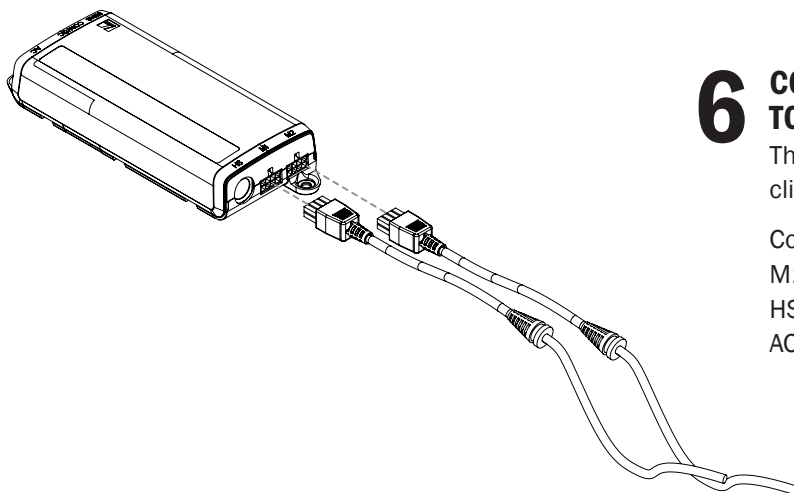

6 CONNECT THE MOTOR CABLES TO THE CONTROL BOX

The motor cable plug-connection has to click into place.

Connections to the control box:

M1-M2 = Connectors for the columns

HS = Connectors for the handset

AC = Connector for the power cord

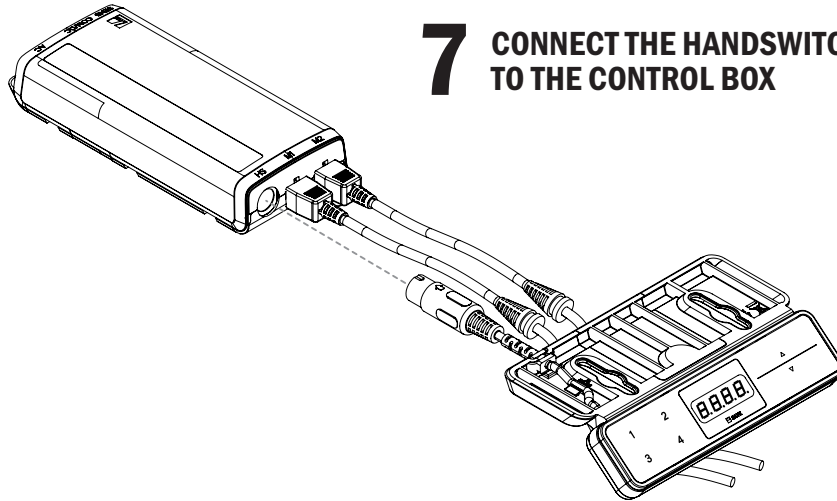

7 CONNECT THE HANDSWITCH (HS) CABLE TO THE CONTROL BOX

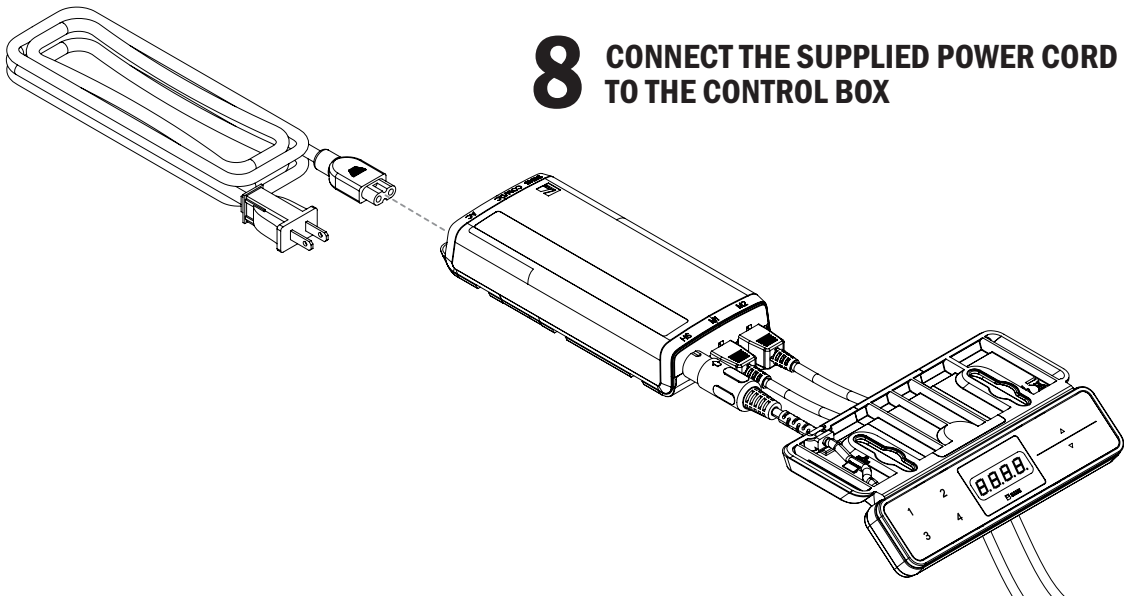

8 CONNECT THE SUPPLIED POWER CORD (AC) TO THE CONTROL BOX

9 ATTACH ALL CABLES TO THE TABLE TOP AND/OR PLACE IN CABLE TRAY.

Attach cables in order to avoid any damage during operation. **Never attach cables and cords to legs.**

OPERATION INFORMATION

INITIALIZATION/RESET

The desk must be initialized/reset after any of the following:

- After assembly
- After disconnection from the power supply
- After any impact on the table top.

To initialize/reset, move the table to the lowest position by pressing the DOWN button on the handswitch until the columns reach the lowest position. Press the DOWN button again until the table moves slightly down to the machine zero point and back up to the operation zero point. Release the DOWN button. If the button is released too soon, the table legs will not move up. Repeat the reset process.

The control box is programmed with a parameter file which controls the table legs' lower and upper travel limits.

Under no circumstance should a control box from one table be moved to another.

NORMAL HANDSWITCH OPERATION (for all handswitch types)

By pressing the UP or DOWN buttons, the table will move up or down to the desired position. Once the desired position is reached, let go of the UP or DOWN button. The table legs will stop once they reach the lower or upper height limits.

PROGRAMMABLE HANDSWITCH OPERATION

This programmable handswitch is equipped with a display for showing the current table height in centimeters or inches.



The handswitch also will display an error code if an error is detected by the control box. When an error is detected, the display will show an error code "EXX," instead of the current table height. To resolve the error, see the Troubleshooting Section (p. 15-16 of this guide).

The programmable handswitch also has the ability to save up to four different height positions.

PROGRAMMABLE HANDSWITCH OPERATION (continued)

CHANGE THE HEIGHT UNIT (inches or centimeters)

The handswitch can display the table height in either centimeters or inches. With the help of the S5-menus, the unit of measure can be changed.

To change the unit of measure, follow these steps:

1. Press and hold the 1, 2, and UP buttons until the display shows “S 5”.
2. Confirm by pressing the “S” button. Now the display will have changed.

To exit the menu without making a selection, wait until the height display appears again.

CHANGE THE HEIGHT DISPLAY

If the displayed value does not match the actual height of the table top, the display can be corrected as follows:

1. Press and release the “S” button.
2. Press and hold the DOWN button until the display starts to flash.
3. Change the height shown on the handswitch by pressing the UP or DOWN button to the desired height. Confirm by pressing the “S” button.

To exit the menu without making a selection, wait until the height display appears again.

SAVE MEMORY POSITION

1. Move the table up or down to the desired height.
2. Press the “S” button (in the display “S -” is shown.)
3. Select a position by pressing one of the four number buttons, 1-4, (the display will show the setting as “S1”).
4. The saved position is confirmed by a double click sound from the control box. The display shows the current table height. Repeat steps to save a maximum of four different positions.

RECALL MEMORY POSITION

Press and hold the desired memory button (1, 2, 3 or 4) the table moves from the current position into the saved position. The button must be pressed until the position is reached. If the button is released, the table will stop short of the desired height.

TROUBLESHOOTING

UNIT

ERROR CODE	SOURCE	SOLUTION
Table does not move	No power supply	Plug in the power cord or check the connection on the control box
	No connection or a loose connection to the drives	Verify the plug connections of the motor cable to the control box
	No connection or a loose connection to the handswitch	Verify the plug connections of the motor cable to the control box
	Max lifting capacity is exceeded	Reduce the weight or load on the desktop
	Max time limit is exceeded	Control is activated automatically after approx. 9 minutes
	Defective drive	Contact customer service
	Defective control box	Contact customer service
	Defective handswitch	Replace the handswitch
Table moves down at a slow rate	Control box expects new reset	Reset control box. (See page 13)
During operation, tables moves at a slow rate	Max lifting capacity is exceeded	Reduce weight
Table moves on one side only briefly and then stops	No connection or a loose connection to the drives	Verify the plug connections of the motor cable to the control box and reset the control box
	Defective drive	Contact customer service

HANDSWITCH DISPLAY

ERROR CODE	SOURCE	SOLUTION
HOT	The control box monitors the duty cycle (time-controlled) and its max temperature. A value has been exceeded.	Wait until the "HOT" display goes out - the table is working properly again
E00	M1 - Internal Fault	Unplug and contact customer service
E01	M2 - Internal Fault	
E02	M3 - Internal Fault	
E12	M1 - Defect	Unplug. Correct the external short circuit and/or verify the cable to the drives. Plug cables into the control box and re-run table.
E13	M2 - Defect	
E14	M3 - Defect	
E24	M1 - Overcurrent	Collision → resolve if necessary
E25	M2 - Overcurrent	Max load exceeded → remove excess load from the table
E26	M3 - Overcurrent	If the problem still exists, please contact customer service
E36	M1 - Not connected	Motor not connected. Check cable / connector to the drive. Reset the table (see page 13).
E37	M2 - Not connected	
E38	M3 - Not connected	
E48	Overcurrent drive 1	Collision → resolve if necessary
E49	Overcurrent drive 2	Max load exceeded → remove excess load from the table
E55	Drive 1 - Synchronization is lost	If necessary, reduce the load on the table
E56	Drive 2 - Synchronization is lost	Reset the table (see page 13)
E60	Collision identified	Option ISP function. Remove source.
E61	Drive replaced	The connection to the drive is interrupted or a new drive is connected. Reset the table (see page 13).

If it is not possible to resolve an error as described, disconnect the power cord, wait a few minutes and reset the table again.
If the error still occurs, remove the table from the power source and contact customer service.

(Error Code list is valid from firmware 1.7.5 and higher)

TECHNICAL DATA

GENERAL CONTROL BOX	
Power supply	120 VAC \pm 10% / 60 Hz
Standby power consumption, primarily	<0.3 W
Operating temperature	0-35°C
Protection class	IP 20
Maximum power output (rated)	240 watts

TWO-COLUMN FRAME WITH CONTROL BOX	
Maximum lift capacity	211 lb (\approx 96kg / 941N)
Adj. range	18in (444mm) View Illustration A
Maximum input current	5 A
Maximum duty cycle	5% (1 min. on / 18 min. off)

ILLUSTRATION A

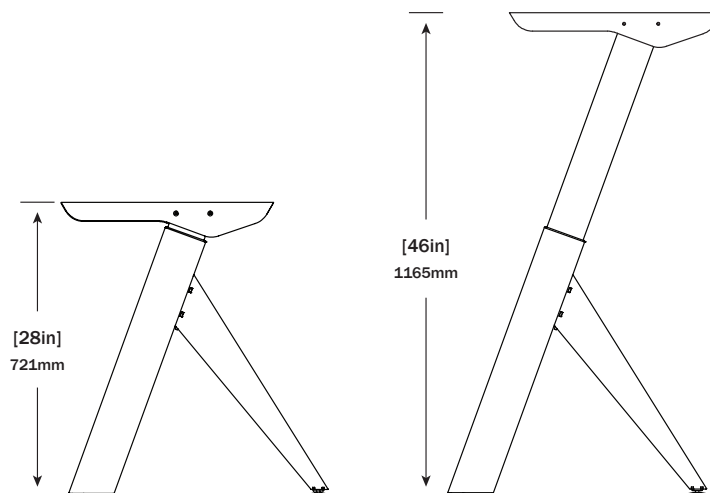

STANDARDS & CERTIFICATIONS

The drive system is tested according to the following standards:

Meets BIFMA X5.5 2014.

WARRANTY

CONTACT YOUR SALES REPRESENTATIVE FOR WARRANTY INFORMATION

INTERTEK LISTING BELONGS TO: System: Lambda
OMT-Veyhl USA
11511 James Street
Holland, MI 49424



End of life cycle: Once product is disassembled, all steel components can be recycled at your local metal collector. For products with electronic components, see Disassembly Guide.



USER GUIDE